

SPE-P1

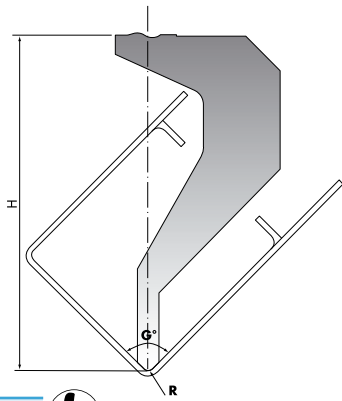

SPE-P1

SPE-P2

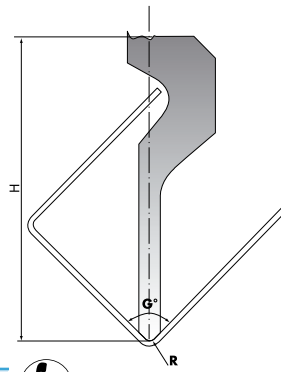

SPE-P2

SPE-P3

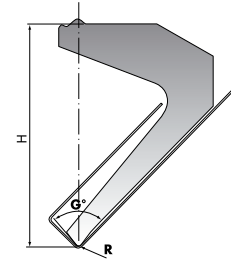

SPE-P3

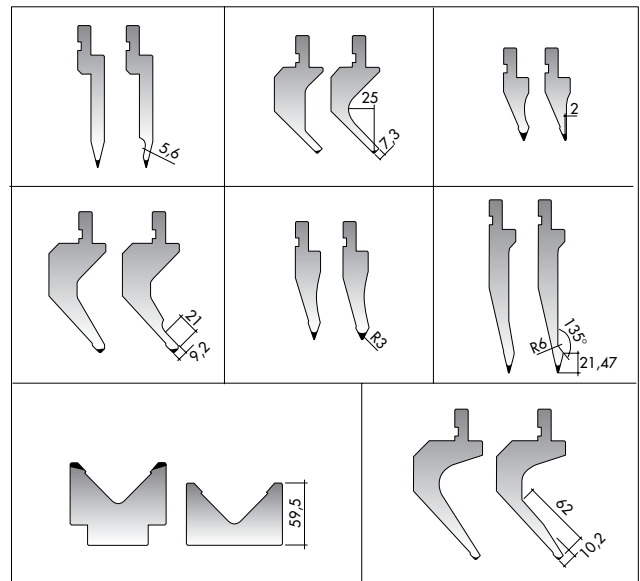
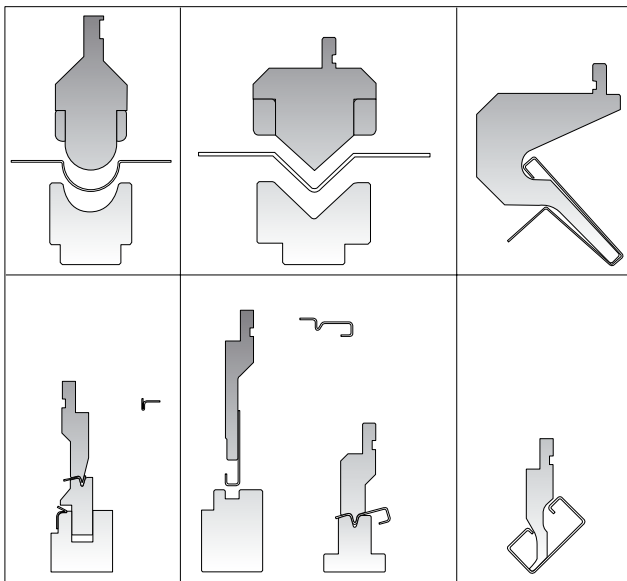

SPECIAL TOOLS

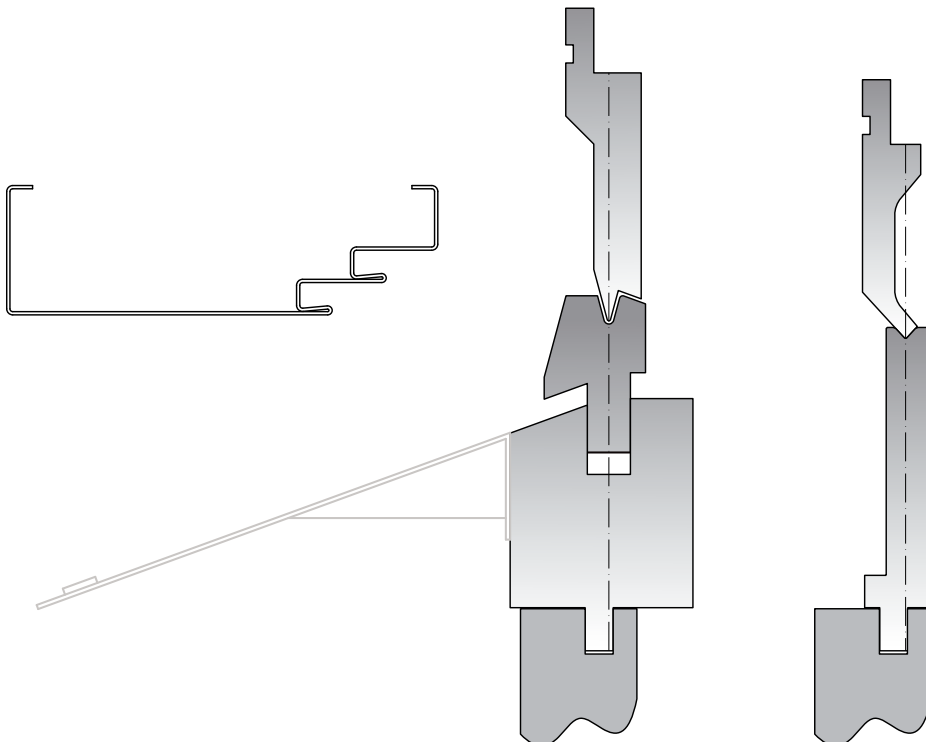

MR90-20-78 ÷ MR 90-70-78 C45

835

○ HRC 60-62

~~F~~

	V mm	B mm	C mm
MR90-20-78	20	45	6
MR90-24-78	24	49	6
MR90-30-78	30	60	8
MR90-40-78	40	70	8
MR90-50-78	50	84	10
MR90-60-78	60	94	10
MR90-70-78	70	104	10

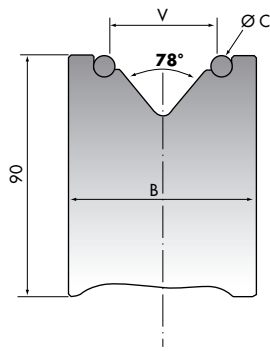

MR130-20-78 ÷ MR 130-120-78 C45

835

○ HRC 60-62

~~F~~

	V mm	B mm	C mm
MR130-20-78	20	45	6
MR130-24-78	24	49	6
MR130-30-78	30	60	8
MR130-40-78	40	70	8
MR130-50-78	50	84	10
MR130-60-78	60	94	10
MR130-75-78	75	118	16
MR130-80-78	80	123	16
MR130-90-78	90	133	16
MR130-100-78	100	143	16
MR130-120-78	120	163	16

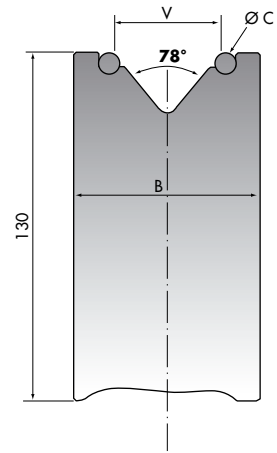

A10

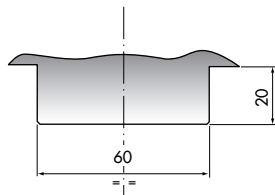

A10

A11

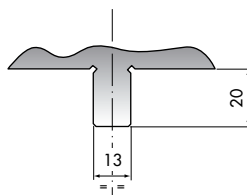

A11

A13

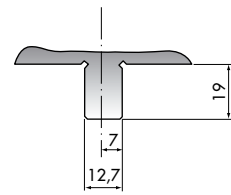

A13

TOOLS FOR PANELLING MACHINE



SPECIAL TOOLS